

# Trusted technical information for the automotive aftermarket

Comprehensive | Innovative | Business focused



# About us

## What we do

Autodata is Europe's leading supplier of technical information to the automotive aftermarket; supporting the service, maintenance, diagnostics and repair of vehicles.

With over 40 years of experience, our trusted workshop applications are widely acknowledged as the most comprehensive and innovative solutions on the market.



**175**  
manufacturers

**360K**  
wiring diagrams

**1050**  
new models  
added in last  
12 months

**40K**  
total updates  
in the last  
12 months

**42K**  
models

**600K**  
step-by-step  
technical  
procedures

**99%**  
coverage of  
cars on the  
road

# Powering your diagnostics

As well as standard OE information in the DTC module, additional common faults and fixes are also displayed when identified. This means the most common problems can be identified instantly.

To take the next step in diagnostics Assist Me, a step-by-step diagnostic feature, provides a path to accurately dive deeper into more unique diagnostic issues, helping quickly identify problems. It all means more accuracy, less time wasted and happier customers.

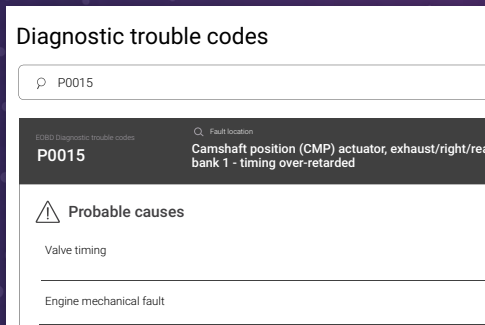

## Step 1

Input the fault code into Autodata's Diagnostic Trouble Codes module.

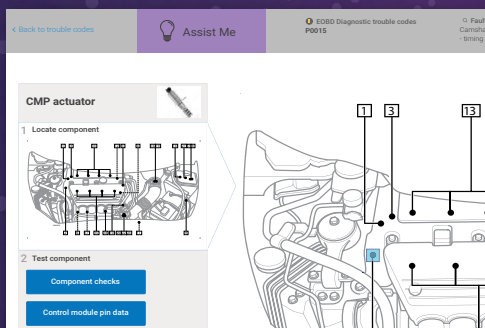

## Step 2

The DTC module will show a list of probable causes and known fixes. This may be all you need to identify and fix the fault in your customer's car.

## Step 3

If not, click through to the new Assist Me feature and locate the faulty component.

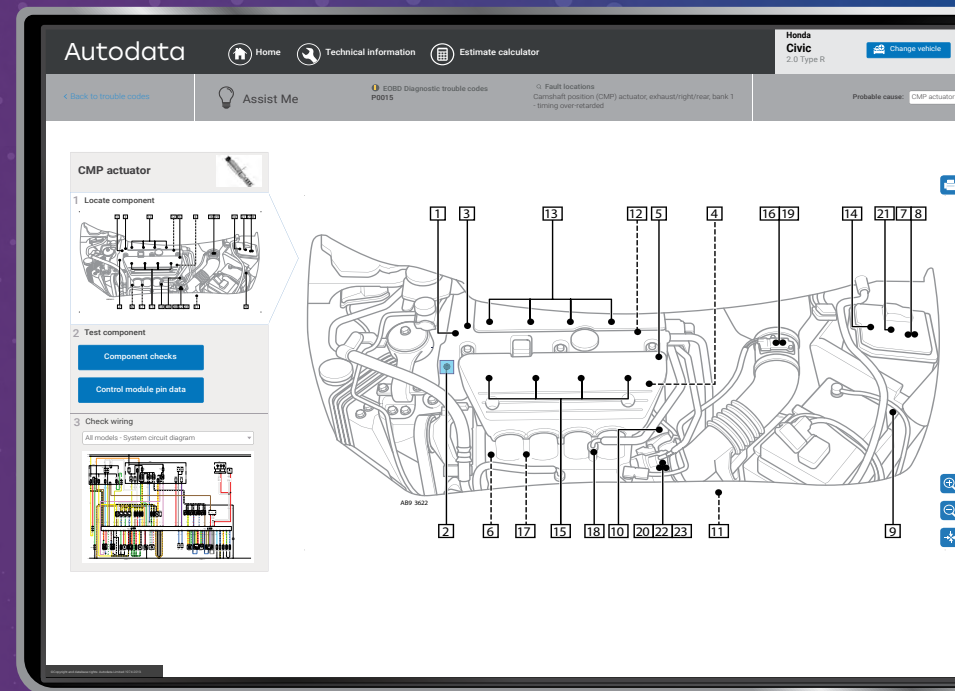

# Powering your diagnostics

As well as standard OE information in the DTC module, additional common faults and fixes are also displayed when identified. This means the most common problems can be identified instantly.

To take the next step in diagnostics Assist Me, a step-by-step diagnostic feature, provides a path to accurately dive deeper into more unique diagnostic issues, helping quickly identify problems. It all means more accuracy, less time wasted and happier customers.

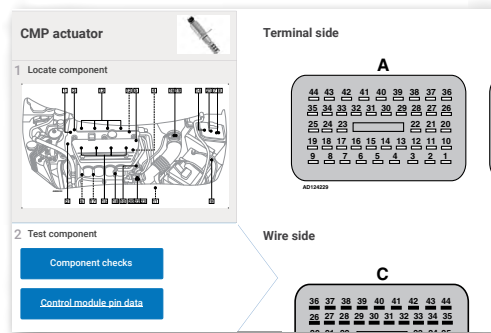

## Step 4

Test the component using the Component Checks and Control Module Pin Data tabs.

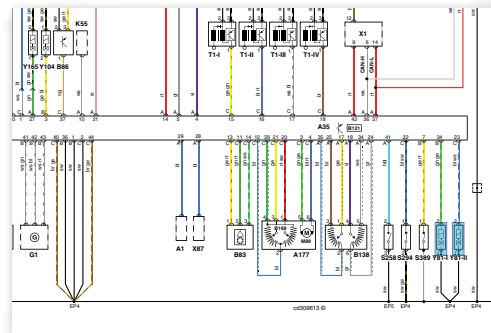

## Step 5

Autodata's full colour and interactive wiring diagrams enable you to deep dive, including full wiring routes and connected components.



# Key features & benefits

Accessing accurate technical information quickly and easily is vital for any workshop to operate a respected and profitable business.

Autodata has a continuous development programme to provide you with a purpose-built online tool that is accurate, fast and easy to use.

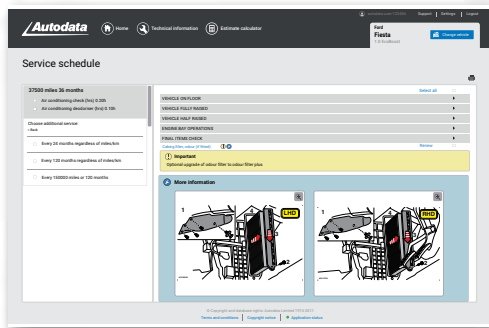

Everything you need – embedded directly into service schedules

We provide official manufacturers' service schedules including all operations and related technical data with associated illustrations, all embedded directly into the page to save you time.

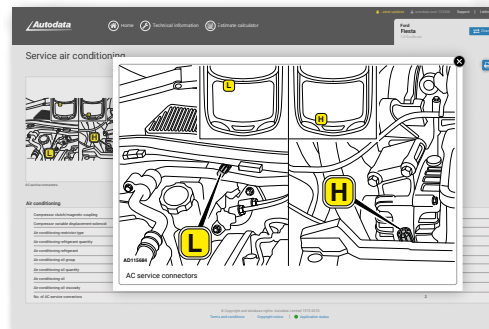

Trusted comprehensive technical data

Autodata's technical information is directly sourced from over 140 manufacturers covering more than 34,000 models worldwide.



Each single license purchased by a workshop location can provide access to 1, 2 or 5 users at the same time, all delivered as a 12-month subscription.

There are no installs or downloads necessary - you just need an internet connection.

Autodata automatically updates, ensuring you have the latest up-to-date technical information whenever you need it.

Your Autodata account is password-protected, making it extremely secure.

# Key features & benefits



## Multi-platform access

Are you a mobile mechanic? Or maybe you need to remind yourself of something while you're under the car.

We understand modern workshops have an array of different technological requirements so all our platforms are automatically accessible on PC, Mac, tablet and smartphone with no downloads or installs necessary.

## Interactive coloured wiring diagrams

Over 17,500 full-colour Wiring Diagrams that allow you to quickly search for components, zoom in and out, select relevant sections and click through for further details and related data.

## Easily swap between jobs

Waiting for that one part to arrive? Start working on another vehicle and then use our popular 'recent activity' tab to quickly revisit the exact page you were looking at when you're ready.

# Key features & benefits

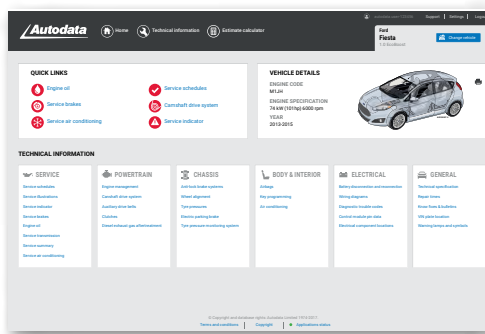

## Quick links

The Quick Links section has been developed to bring you instant access to the six most commonly used modules in Autodata.

Easily access service modules, engine oil information and the camshaft drive system of your chosen vehicle.

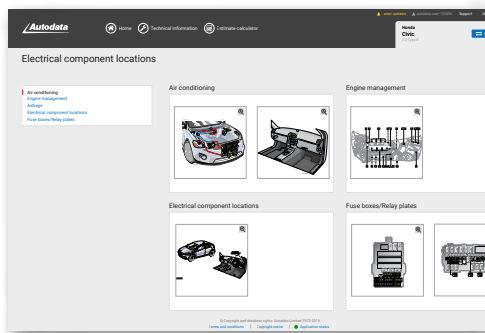

## Component locations

Our interactive Component Locations page allows you to quickly search for components, see images and access dedicated component information pages quickly and without fuss, saving you valuable time.



# Subscriptions

PRODUCT FEATURES	Service & Maintenance	Diagnostic & Repair
<b>Service guides</b> Official manufacturers' schedules Service Advisor Service illustrations Service indicator Service air conditioning Engine oil Service transmission Service brakes	✓	✓
<b>Maintenance procedures</b> Drive belts/chains replacement Electric parking brake release TPMS Key programming Battery disconnection & reconnection	✓	✓
<b>Technical specifications</b> Repair times Tyres & wheel alignment Fluids & lubricants Tightening torques General component locations Fuse boxes & relays Bulb replacement	✓	✓
<b>Diagnostics &amp; troubleshooting</b> Diagnostic trouble codes Assist me Wiring diagrams Control module pin data Electrical component locations Component testing Known fixes & bulletins		✓
<b>Vehicle systems &amp; repair information</b> Engine management Clutches Diesel exhaust gas after treatment ABS/ESP Airbags Air conditioning		✓



## Diagnostic & repair

The full version of Autodata with in-depth and detailed information you need to carry out more complex diagnostics and repair procedures as well as service and maintenance procedures.

## Service & maintenance

The information you need to carry out day-to-day servicing.

Visit [www.autodata-group.com](http://www.autodata-group.com) to get started

It's quick and easy to set up your Autodata subscription. You can be set up and logged on in under five minutes.



# Autodata for motorcycles

Firmly established as the workshop's bible for routine motorbike servicing and repairs, Autodata for Motorcycles provides quick and easy access to the technical information your workshop needs – all presented in the same trusted, clear and easy-to-use format.

Autodata for Motorcycles is fully online and can be easily added to your existing Autodata subscription or purchased as a standalone.



**1400**  
new models  
added in last  
12 months

**70**  
manufacturers

**4000**  
repair times

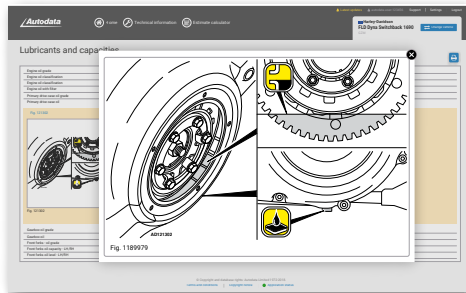

## Lubricants & capacities

Check oil grades and classifications with our Lubricants module.

View specific types of oil and overall capacities all in one place.

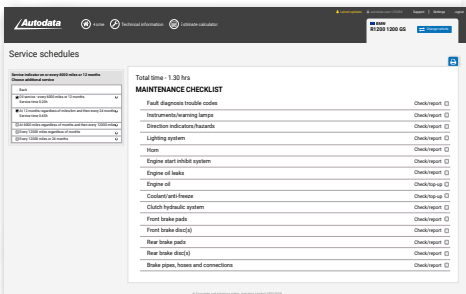

## Official service schedules

New to Autodata for Motorcycles. Look up the official manufacturer service schedules.

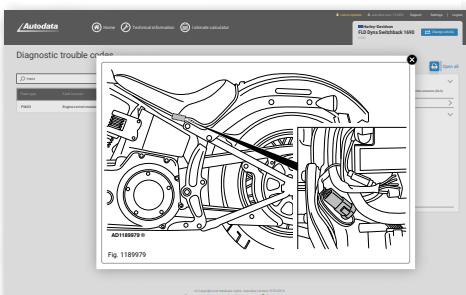

## DTC module

The diagnostic trouble codes module enables fast and easy troubleshooting with an error codes search function, data link connector location, fault locations and probable causes.

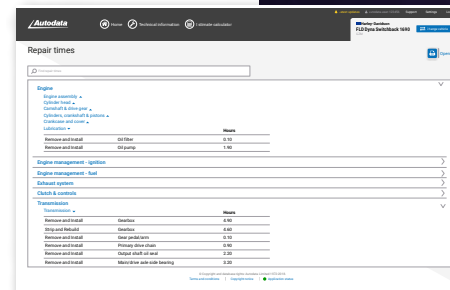

## Motorcycle repair times

Find out the specific manufacturer recommended repair times associated with common fixes, such as engine assembly, exhaust systems, suspension, brakes and many more.

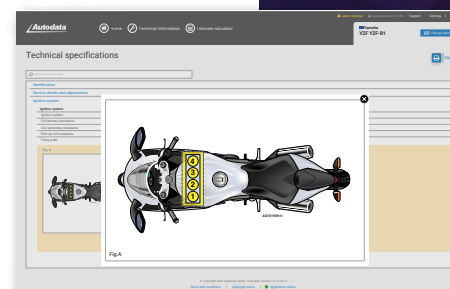

## Technical specifications

All the technical specifications you need at your fingertips: identification, spark plugs, kerb weights and many more, with search functionality for easy access.



Visit us online for more information  
[www.autodata-group.com](http://www.autodata-group.com)

+44 (0)1628 688111  
[sales@autodata-group.com](mailto:sales@autodata-group.com)

Interested in integrating Autodata visit  
[developer.autodata-group.com](http://developer.autodata-group.com)